

RB 1200

Residential Regulator

Applications

The RB 1200 regulator is designed for residential and light commercial applications. Its valve design makes it specially suitable for medium-pressure service lines where it accommodates large inlet pressure variations while keeping very constant outlet.

The RB 1200 offers two connection styles providing flexibility for meter mounting or integration in compact meter boxes.

Description

The RB 1200 regulator is a spring-loaded self-operated regulator with internal relief and a safety shut-off device. It is fitted with an inlet strainer. The safety shut-off valve cuts the gas flow when the outlet pressure exceeds the set pressure (OPSO) or when it drops below the set value (UPSO). It remains closed until the valve is reset manually. Its internal relief valve (SRV) avoids triggering the safety shut-off valve in case of thermal expansion, transient surges of pressure, and creep leaks from regulator.

Technical Features

Maximum inlet pressure	10 bar
Outlet pressure	13 mbar – 135 mbar
Accuracy & lock-up pressure	Up to AC5 / up to SG10
Operating temperature	-20°C to +60°C
Acceptable gases	Natural gas, propane, butane, air, nitrogen
Safety devices	Standard relief valve Optional built-in safety shut-off valve: - Over-pressure shut-off (OPSO) - Under-pressure shut-off (UPSO)

Sizes & Connections

Sizes	DN 20 combi-body or DN 32 in-line body
Connection	Combi-body: internal thread ISO 7 - Rp 3/4 In-line body: external thread ISO 7 - Rp 1 1/4

Materials

Body/Actuator	Die cast aluminium
Seals	Nitrile
Diaphragms	Nitrile

Option Designations

RB 1210	with SRV
RB 1211	with OPSO and SRV
RB 1212	with OPSO, UPSO and SRV

Operating Principle

The pressure reduction takes place between the seat and the tubular nozzle (1). The valve disc position is controlled by the diaphragm (2) which senses the outlet pressure on one side and is loaded by the spring (3) on the other side. The spring load is adjustable by the nut (4). The cap (5) can be sealed to prevent unauthorized intervention.

By design the tubular nozzle is balanced against inlet pressure differentials.

Safety

The slam shut valve (7) shuts the gas flow off tight in case of excess of outlet pressure, which is sensed by the diaphragm (8). The load of the shut-off valve spring (9) is adjustable by the nut (10). The cap (11) can be sealed to

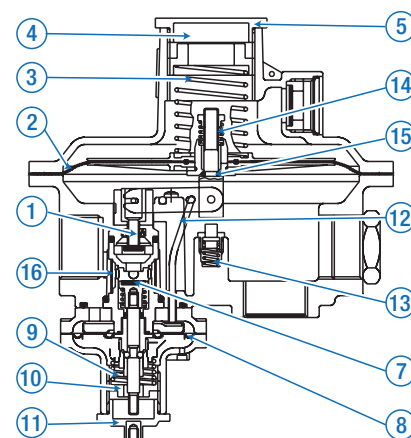

prevent unauthorized intervention. Optionally, the rod (12) controlled by the diaphragm assembly triggers the slam shut valve when outlet pressure drops below a set point defined so as to overcome the load of spring (13). The set point is factory preset and cannot be adjusted on site.

A safety relief valve is built into the diaphragm assembly. When the outlet pressure build-up over the set point exceeds the load of the spring (14), the diaphragm plate moves while the stem is stopped, thus opening a passage between the orifice (15) and the plug.

Gas is released to atmosphere through the breather tap.

A 100 µm strainer (16) protects the regulator on the inlet side.



> B 1200 with built-in safety shut-off valve

- > For residential applications
- > Angle or in-line design
- > Built-in shut-off valve
- > Internal relief
- > Inlet strainer
- > Adjustable on site

Typical Regulation Curve (22 mbar set point)

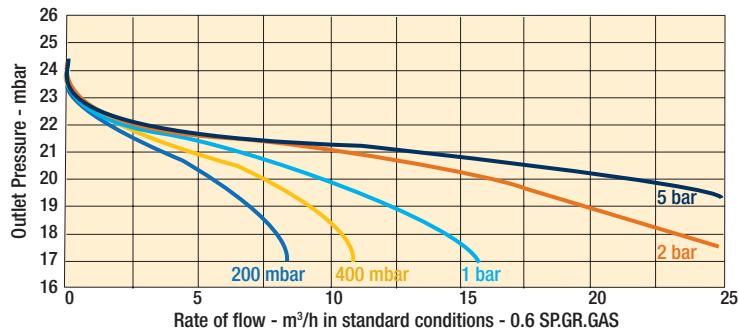

Outlet Pressure Range

Regulator

Spring Code	Spring Characteristic				Spring Range
	d (mm)	De (mm)	Lo (mm)	Lt	
20564241	1.5	30	80	9.5	13 - 20 mbar
20564141	1.6	30	80	9.5	18 - 29 mbar
20564243	1.7	30	80	7.5	27 - 46 mbar
20564142	1.8	30	80	8.5	31 - 52 mbar
20564050	1.8	30	100	10	45 - 60 mbar
20564051	2	30	100	11.5	60 - 85 mbar
20564044	2.2	30	80	9	82 - 135 mbar

Safety Shut-off Valves

Over Pressure Shut-off Springs (OPSO)

Spring Code	Spring Characteristic				Spring Range
	d (mm)	De (mm)	Lo (mm)	Lt	
20561915	0.9	18	25	6.5	30 - 41 mbar
20562018	1	18	25	6.5	38 - 56 mbar
20562015	1	18	30	6.5	55 - 80 mbar
20562020	1.1	18	30	6.5	70 - 120 mbar
20562019	1.2	18	25	5.5	115 - 135 mbar

Under Pressure Shut-off Springs (UPS0)

The set point of the under-pressure shut-off valve is not adjustable and is preset at the factory. The differential pressure between the regulator and UPS0 set points is indicated in the following table. The level of pressure differential - low, medium, high - can be selected to suit the application.

Reg Spring Code	Differential (mbar)			Reg Spring Code	Differential (mbar)		
	Low	Med	High		Low	Med	High
20564241	8	15	20	20564050	20	25	30
20564141	10	20	25	20564051	40	50	55
20564243	25	35	40	20564044	55	65	70
20564142	20	30	35				

Relief Valve

Spring Code	Relief Set Pressure*
955-203-36	10 mbar over set point

* Other settings available on request

Flow Capacity

RB 1200 set at 22 mbar - model with built-in SSV

Inlet Pressure	Capacities (m³/h) at Standard Conditions
200 mbar	7
400 mbar	10.5
1 bar	14
2 bar	20
4 bar	30

Capacities at 4 mbar droop.

Spring characteristics:

- d : wire diameter
- De: external diameter
- Lo : height
- Lt : no. of spires

Standard conditions:

- Absolute pressure of 1.013 bar
- Temperature of 15°C

Correction factor for non-natural gas applications:

The flow rates are indicated for a 0.6 specific gravity gas.

To determine the volumetric flow rate for gases other than natural gas, multiply or calculate the values in the capacity tables using the sizing equations with a correction factor.

The table below lists correction factors for some common gases:

Gas type	Specific gravity	Correction factor
Air	1.00	0.77
Butane	2.01	0.55
Carbon dioxide (dry)	1.52	0.63
Carbon monoxide (dry)	0.97	0.79
Natural gas	0.60	1.00
Nitrogen	0.97	0.79
Propane	1.53	0.63
Propane-Air mix	1.20	0.71

Specific gravity or relative density (air = 1, non-dimensional value)

Use the following formula to calculate the correction factor for gases not listed above. In the formula, d is the specific gravity of the gas.

$$\text{Correction factor} = \sqrt{\frac{0.6}{d}}$$

Overall Dimensions & Fittings

Various additional fittings are available for inlet and outlet connections as shown below. Other possibilities can be provided on request.

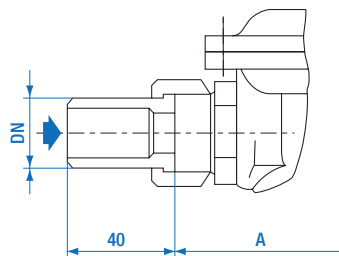

> Fig 1

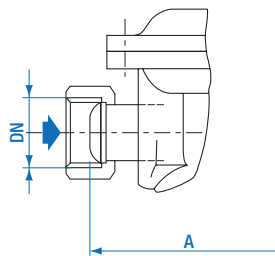

> Fig 2

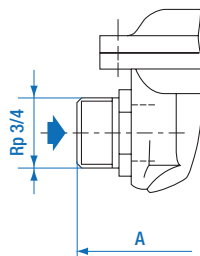

> Fig 3

Inlet fitting type	See Fig	A (mm)
Three-piece coupling welded on DN 20 pipe	1	104
Three-piece coupling welded on DN 25 pipe	1	113
DN 20 sphero-conical coupling	2	110
DN 25 sphero-conical coupling	2	115
External thread ISO Rp-3/4	3	107

Outlet fitting type	
Gas meter union	G 1 1/4
External thread ISO R7	Rp 3/4

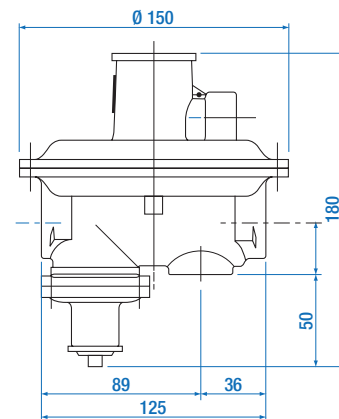

> Mod. 1211-1212 - Weight 1.1 Kg

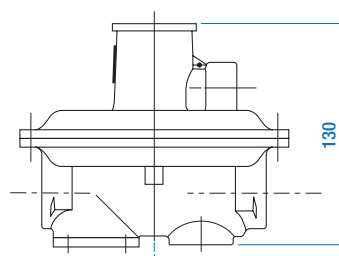

> Mod. 1210 - Weight 1 Kg

Installation

Gas must flow through the valve body in the same direction as the arrow cast on the body. The RB 1200 regulator can be mounted in any position. The set point must be adjusted slightly if the regulator is positioned so that the loading spring is not vertical and pointing upwards.

When changing the connection style (in-line or angle), ensure there are no leaks and that all connections are tight.

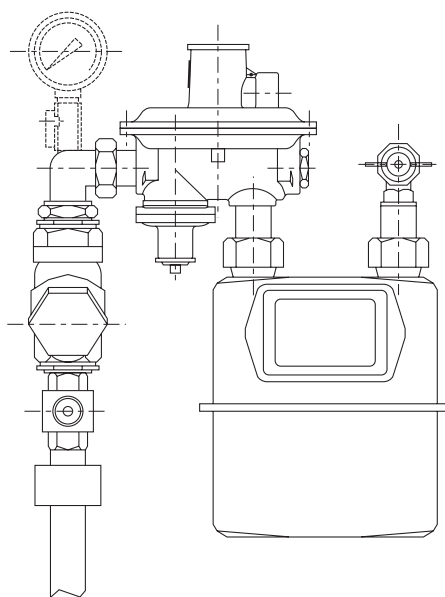

> Typical meter box installation

Information to be specified when ordering:

- Regulator type code
- Minimum and maximum inlet pressures
- Outlet pressure range
- Outlet pressure setting
- Connection type
 - OPSO setting*
 - UPSO setting*
- * (if requested)

About Itron Inc.

Itron Inc. is a leading technology provider to the global energy and water industries. Our company is the world's leading provider of metering, data collection and utility software solutions, with nearly 8,000 utilities worldwide relying on our technology to optimize the delivery and use of energy and water. Our products include electricity, gas and water meters, data collection and communication systems, including automated meter reading (AMR) and advanced metering infrastructure (AMI); meter data management and related software applications; as well as project management, installation, and consulting services. To know more, start here: www.itron.com

For more information, contact your local sales representative or agency.



Itron GmbH.
Hardeckstraße 2
D-76185 Karlsruhe
Germany
Phone: +49-721 5981 0
Fax: +49-721 5981 189
www.itron.com